



 **SVAGO**TM

SV410 Use and Care Manual

100
95
75
25
5
0

Thank you for purchasing this Svago ZG-Recliner.
To ensure that you don't overlook any of your chair's features, and that you use it safely, read this manual carefully. Then sit back, relax, and enjoy!

TABLE OF CONTENTS

IMPORTANT SAFETY INSTRUCTIONS	1-2
CHAIR COMPONENTS	3
CHAIR SPECIFICATIONS	4
CHAIR DIMENSIONS	5
PLACING THE CHAIR	6
INSTALLATION	7-9
PREPARATIONS PRIOR TO USE	10
PROGRAM OPERATION GUIDE	11-13
MAINTENANCE PROCEDURES	14
TROUBLESHOOTING	15
WARRANTY INFORMATION	16-18
Warranty Card (Attachment)	

100
95
75
25
5
0

IMPORTANT SAFETY INSTRUCTIONS

When using an electrical appliance, basic precautions should always be followed, including the following:

DANGER: To reduce the risk of electrical shock, always unplug Svago™ from the electrical outlet immediately after using and before cleaning.

WARNING: To reduce the risk of burns, fire, electric shock or injury to persons:

- Do not put hands or fingers near the footrest mechanism on the under side of the chair while this product is running. Touching the mechanism can result in injury.
- If the supply cord is damaged, it must be replaced by the manufacturer or its service agent or a similarly qualified person in order to avoid a hazard.
- An appliance should never be left unattended when plugged in. Unplug from outlet when not in use, and before putting on or taking of parts.
- Close supervision is necessary when this product is used by, on, or near children, in valids, or disabled persons. Keep children away from extended foot support (or other similar parts).
- Use this product only for its intended use as described in this manual. Do not use at attachments not recommended by the manufacturer.
- Never operate this product if it has a damaged cord or plug, if it is not working properly, if it has been dropped or damaged, or dropped into water. Return this product to a service center for examination and repair.
- Do not carry this appliance by supply cord or use cord as a handle.
- Always keep the power cord away from heated surfaces.
- Never operate this product with the air openings blocked. Keep the air openings free of lint, hair, and the like.
- Never drop or insert any object into any opening.
- Do not use outdoors.
- Do not operate where aerosol (spray) products are being used or where oxygen is being administered.



- Do not use this product when standing on a damp floor, or when any part of the body is in contact with plumbing or any similar ground.
- Do not use this product if noise above normal sound is heard.
- Do not stand on or in appliance. Use only while seated.
- This appliance is not intended for use by persons (including children) with reduced physical, sensory or mental capabilities, or lack of experience and knowledge, unless they have been given supervision or instruction concerning use of the appliance by a person responsible for their safety.

Children should be supervised to ensure that they do not play with the appliance. Please consult your doctor if you have any doubts about using this chair or if you are pregnant, undergoing medical treatment, using a medical electronic device or are receiving oxygen.

- Comfortable clothing is recommended while using this product.
- If you feel any abnormal discomfort during the operation of this product, turn off the power immediately and do not use the product. Consult your physician.
- **Do not pull on the AC cord.**
- When using this product after it has been in storage, check to see that the product is operating properly prior to use. • Always confirm that there are no obstacles behind the product and that there is sufficient space to recline.
- **Do not attempt to repair this product yourself.**
- This product is designed for personal in-home use.

Commercial use will void warranty.

- To reduce the risk of electric shock, this appliance has a polarized plug (one blade is wider than the other). This plug will fit in a polarized outlet only one way. If the plug does not fit fully in the outlet, reverse the plug. If it still does not fit, contact a qualified electrician to install the proper outlet. Do not change the plug in any way.

CHAIR COMPONENTS

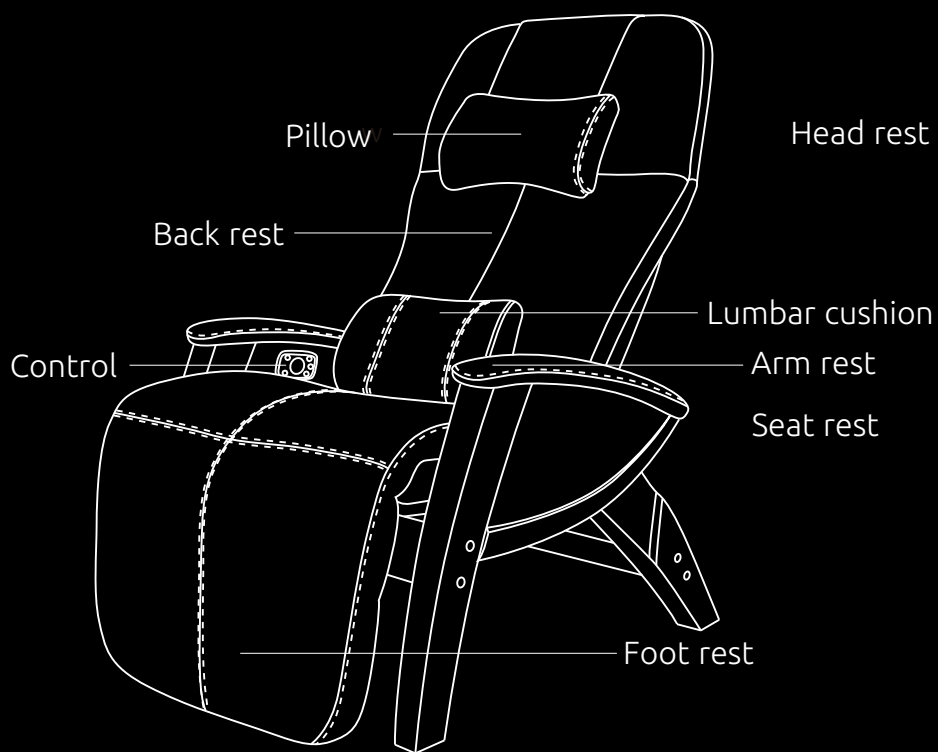

Check the accessories frst

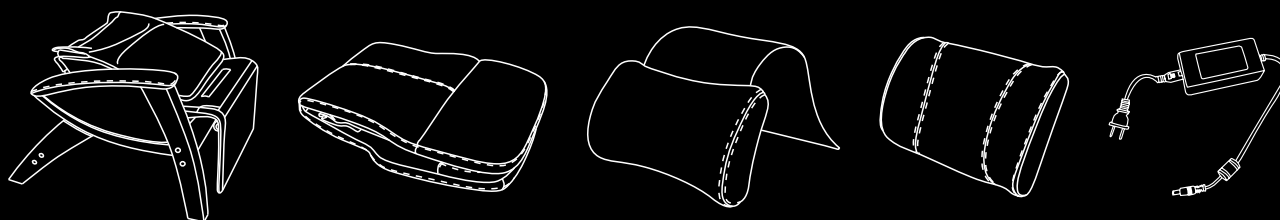

3

100
95
75
25
5
0

CHAIR SPECIFICATIONS

Specifications		Description
Model No.		SV410
Rated Voltage		In-put 110-120V
Rated Frequency		60Hz
Out-put		24V DC 3A
Rated Power Consumption		72W
Auto Timer		15 minutes
Dimensions (L*W*H)		Chair Upright:43.3"x30.7"x47.5"
		Chair Reclined:63"*30.7"*30"
		Packing Carton: 45"*32"*33.9"
Weight	Net Weight	110 lbs
	Gross Weight	150 lbs
Maximum Load Weight		400 lbs
Required Recline Clearance		28"
Usage Condition		Environmental temperature 10°C-40°C Contrasting humidity level 30-85RH
Storage Condition		Storage temperature 20°C-55°C Storage humidity level 30-85RH
Safety Feature		Equipped with overheating and power surge detectors

CHAIR DIMENSIONS

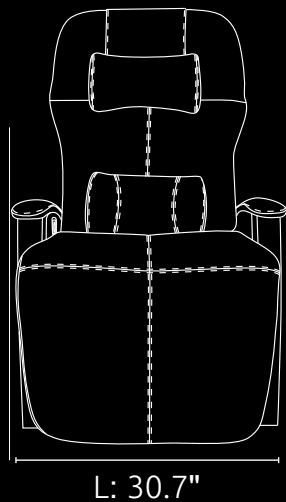
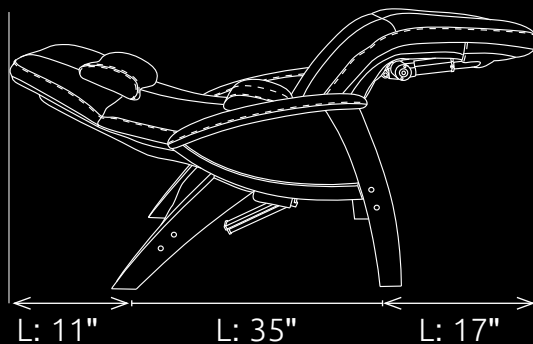
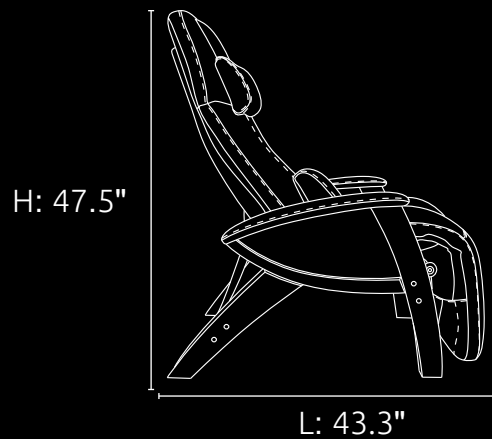

PLACING THE CHAIR

1. Lay a carpet, etc. on the set-up place.
It prevents damaging the floor, and mufes the noise during use.
2. Ensure there is suficient space to allow the chair to recline.
In order not to touch the wall or other things when reclined, allow a clearance of 70cm(28") or more to the front and the back of the chair.

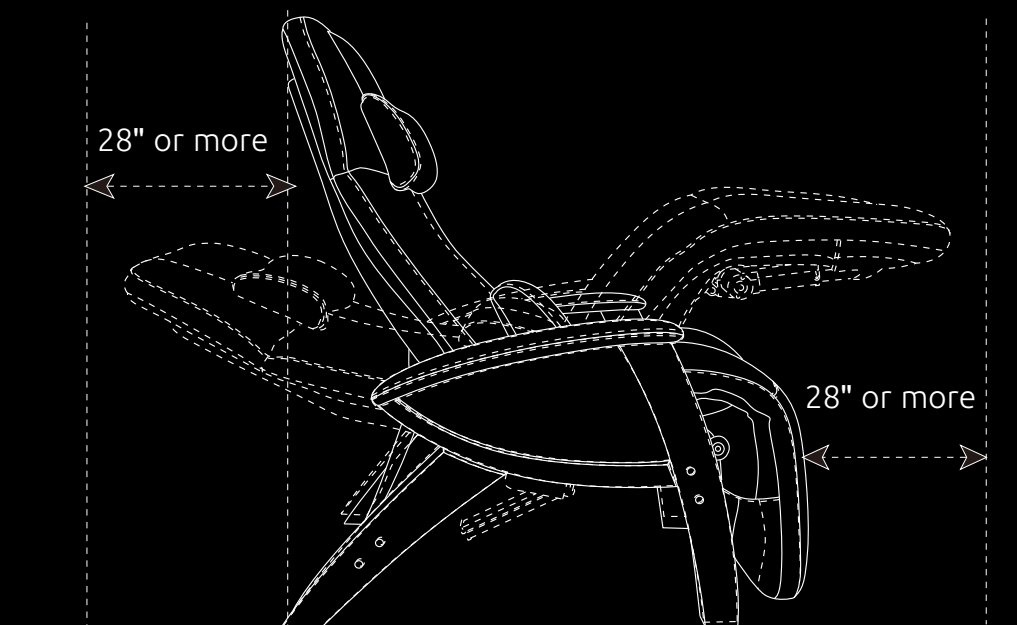

Notes

- Place the chair on a level surface.
- Keep the chair at least 1 meter(3ft) away from AV machines like a TV or radio.
- Do not keep the chair in a place with high humidity like a bathroom.
- Do not keep the chair in a place where it will be exposed to direct sunshine for an extended period, or in a place near a heater where the temperature may reaches high levels.

INSTALLATION

Step 1:

Unpack and lift out the chair.

Step 2:

Unfold the backrest frame, fix the "L" latch, and attach the rear fabric cover by Velcro.

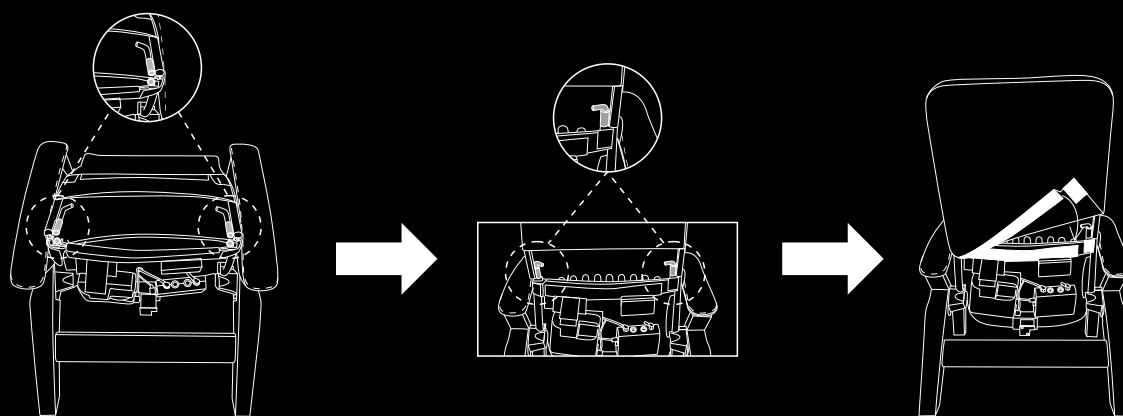

Step 3:

Connect the power source, press the leg-rest-raise button  and lift up the leg rest. Insert the leg frame into the rear pocket of leg-rest cushion. Tidy and attach the seat pad by Velcro.

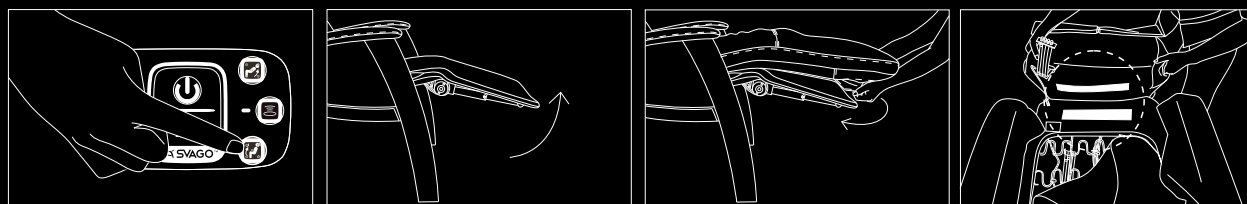

Step 4:

Pull the air hoses in the back pad through the fabric cover pocket on the seat. Please align hoses in the back pad at the connectors. Connect to the connectors and the heat coils, then zip up.



Step 5:

Tidy, pull the seat pad to the seat frame as much as possible, align the Velcro and then attach the seat pad.

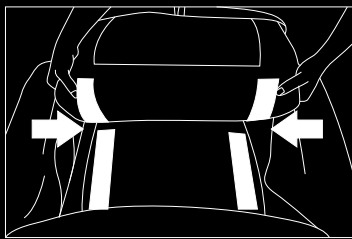

Step 6:

Unzip the rear cover of back pad, put it onto the head rest frame, and then zip up.

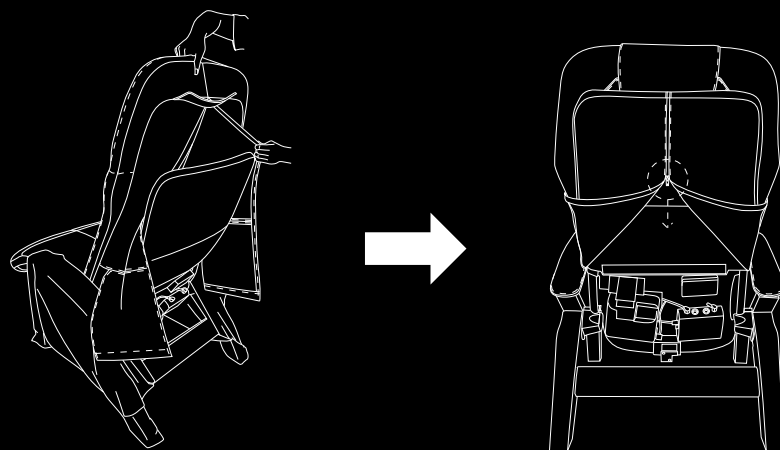

Step 7 :

Attach the pillow to the head rest by the Velcro.



Step 8 :

Place the lumbar cushion on one seat.

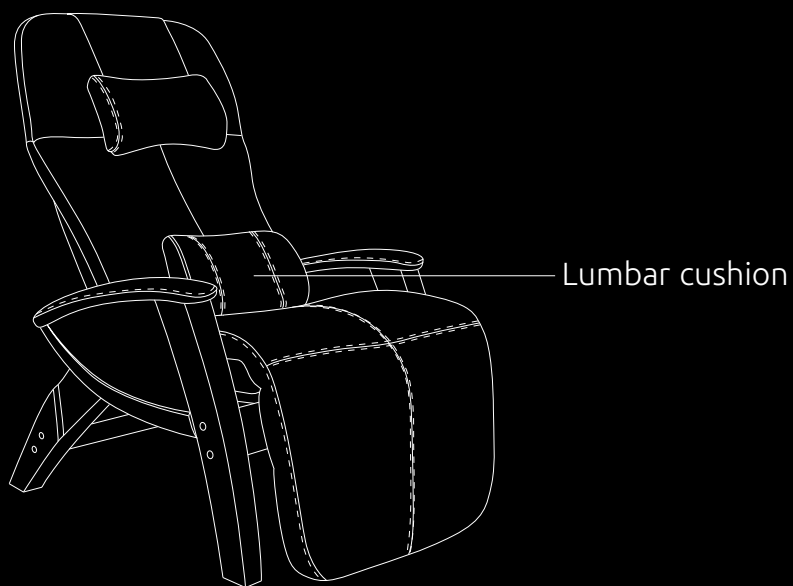

100
95
75
25
5
0

PREPARATIONS PRIOR TO USE

1. Check the cloth of the chair

Prior to use, be sure to check that the cover cloth or the cloth of other parts is not torn. If a tear is found, stop using the chair immediately, unplug the power source, and obtain service. If the chair is used with torn cloth, it may result in injury or electric shock.

2. Check the power cord

Check that there is neither breakage or damage to the power adaptor. Check that the cords are not caught or placed beneath the chair.

3. How to connect the power source.

- 1) Connect the power adaptor with the chair.
- 2) Insert the power plug into an outlet.

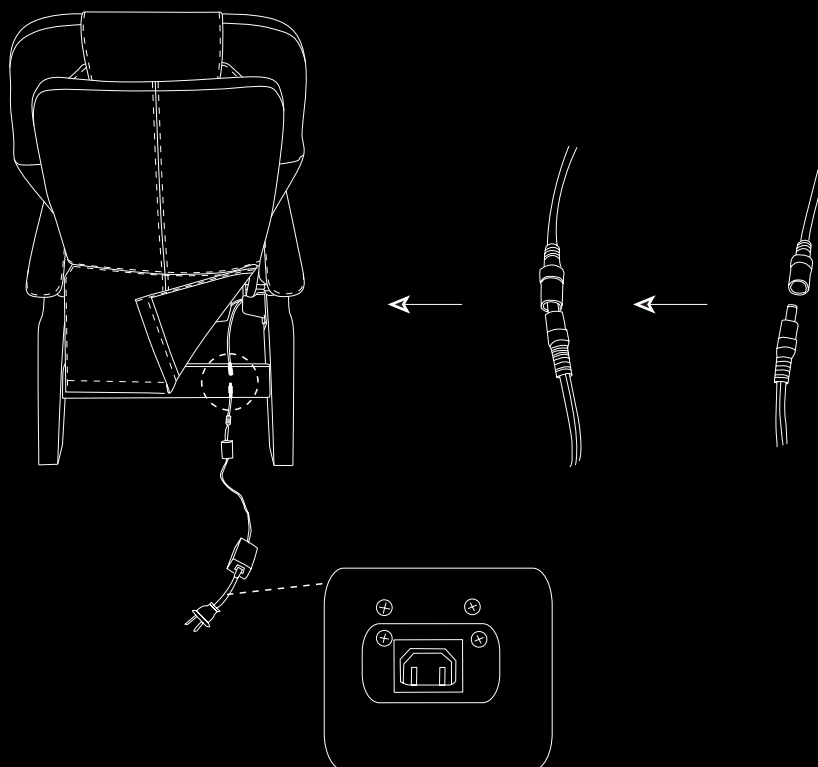

PROGRAM OPERATION GUIDE

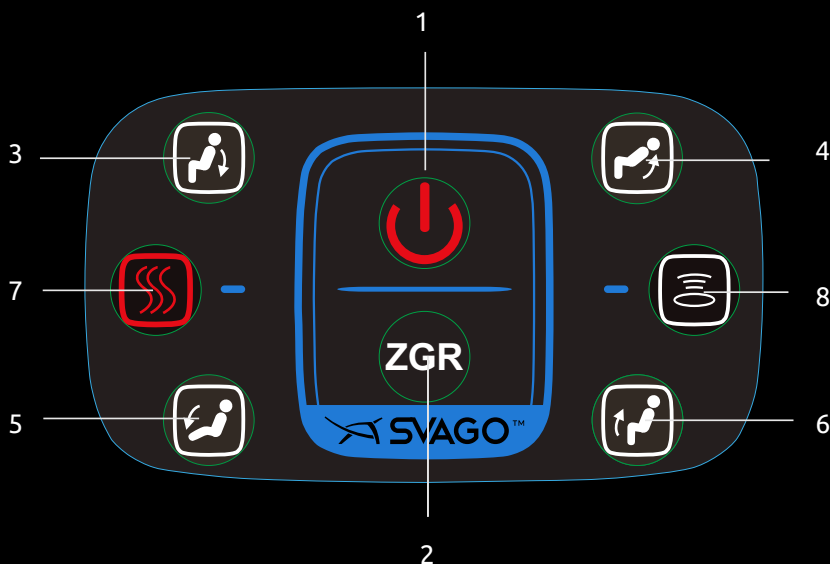

1. On/Of

When you press the button, the ON/OFF lamp illuminates, the chair is in idle, and will start to work when you press any other function buttons.

When you want to suspend the operation in the middle or have felt some abnormality with your body.

Press the on/of button.

Operation stops and all the lamps with extinguish.



2. ZGR **ZGR**

When you press the button, the back rest, foot rest, and seat are automatically adjusted to prearranged reclining angles.

- Reclining can be stopped during the reclining motion by pressing either the ZGR button, Back rest Recline/Restore, or Leg rest Raise/Restore.
- When the reclining motion is stopped by pressing buttons other than the ON/OFF button, press the desired button for motion.
- After achieving the ZGR position, you still may adjust the angles of back rest and foot rest, by pressing the relevant buttons.

3/4. Backrest Recline/Raise

Press the button to activate the back rest motion, and press again when the desired angle is achieved.

- The angle of the seat will be changed automatically in accordance with the angle of the back rest.
- The motion can be stopped by pressing either the ZGR button, or Back rest Recline/Raise.
- During the back rest motion, the chair has no response when you press either Leg rest Raise/Lower, Heating or Vibration.

NOTE:

Be sure to check that there is no-one or any pets around the chair prior to adjusting the back rest. It may result in an accident or injury.

5/6. Leg rest Raise/Lower

Press the button to activate the leg rest motion only, and press again when the desired angle is achieved.

- The motion can be stopped by pressing either the ZGR button, or Leg rest Raise/Lower.
- During the leg rest motion, the chair has no response when you press either Back rest Recline/Raise, Heating or Air massage.

100
95
75
25
5
0

7. Heating

Press the button to start heating located in lumbar and seat center, with the button lamp on.

Press the button again to stop the heating, with the button lamp of.

- Heating will pause during any recline adjustments and will resume automatically after adjustments stop.

8. Air Massage

Four large airbags are built into the chair and independently inflate and deflate in predetermined sequences. They stretch muscles to loosen tension with a soft massage that improves circulation and relieves body fatigue. Press the Air button one time can start it, press second time can stop it.

- Air massage will pause during any recline adjustments and will resume automatically after adjustment stop.

Automatic Shut-of

- The Svago has a 15 minute automatic shut-of function. All operations will stop after 15 minutes and can be re-set by pressing any of the function buttons.

CAUTIONS - AFTER USE

- Bring the chair to its upright position.
- Turn of the power.
- If the chair is not be used for an extended time, disconnect the power cord.

MAINTENANCE PROCEDURE

WARNING

Be sure to disconnect the power plug from the outlet prior to maintenance

NOTE

Do not attempt to use benzene. Thinner alcohol, alkaline detergent or bleaching agent for cleaning, as this may result in deformation, discoloration or cracking.

HEAD REST, BACK PAD, SEAT COVER, ARM REST, FOOT REST, PILLOW(LEATHER)

Perform daily maintenance by wiping with a soft dry cloth. When parts are badly soiled, adopt the following maintenance procedure.

1. Soak a soft cloth in diluted neutral kitchen detergent and squeeze it well. Wipe the main unit with the damp cloth in a tapping motion.
2. Soak a cloth in clean water, and squeeze it well. Wipe of the remaining detergent with the damp cloth.
3. Wipe it with a dry cloth afterwards.
 - Do not force-dry with a drier.
 - Do not force contact with vinyl products for an extended period. It may cause discoloration.

NOTES

- Leather is a natural material, so imperfections grain, dye variations and natural markings do not constitute a defect.
- Polyurethane foam padding tends to soften and light creases may form on the leather cover over a period of three months. These are natural occurrences and do not require any type of maintenance.
- A professional cleaner should be contacted for particular types of stains such as ink marks.

TROUBLESHOOTING

WARNING

If the trouble still persists after following the proper countermeasures, stop using the chair to avoid possible accidents. Disconnect the power plug from the outlet and consult Svago service department. Do not attempt to repair the chair, instead contact a certified technician.

Type of Troubles	Check points	Countermeasures
Operation failure	Check that the power plug is securely plugged into the outlet.	Push the power plug into the outlet securely.
	Check that the power adaptor is well connected to the chair.	Well connect the DC terminals between the chair and power adaptor.
The chair stops in the middle of operation.	This phenomenon is caused by the timer, but not a problem.	
Impossible to recline. Impossible to raise or lower the foot rest.	Check that there is no obstruction.	Remove the obstruction.

If you continue to have problems, please read the warranty card and contact the Svago service department.

WARRANTY INFORMATION

Svago products have the following warranty:

Svago ZG-Recliners provide a one year in home servicing warranty and a two year parts warranty. Svago customer service will not issue Return Material Authorizations (RMAs) for products. In case of missing parts or service issues, please contact the Svago service department. Svago will not issue Return Material Authorizations (RMAs) to buyers.

SERVICE AND TECHNICAL SUPPORT

- Consumers may contact Svago's Customer Service Department at 1-877-977-0756 between 10.00am and 6.00pm EST, Monday through Friday or email us at **service@cozziausa.com** or visit our web site at **www.cozziausa.com** for warrant and service issues.
- Consumers are required to provide the unit serial number and dated proof of purchase (sales receipt) when they contact the Svago service department regarding a repair.
- A Svago customer service representative will attend to most consumer inquiries but in some cases a technical service specialist will be required to provide enhanced support.
- Non warrant repair is provided on a 'per incident' basis. Svago customer service will verify that the unit has failed and provide instructions for repair. All applicable repairs, parts, shipping, handling, local tax and a 'per incident' fee will be charged for non-warranty repairs and support calls.
- Proof of purchase (original receipt) is required for all warranty repairs or servicing.

EXTENDED WARRANTIES

- Svago offers extended warranty programs to enhance ownership of Svago products. Extended warranty provides a three year limited repair or replacement massage chair warranty with on-site service.
- Please visit www.cozziausa.com for the latest terms and pricing for extended warranties.

PRODUCT REPAIRS

- Many Svago parts may be installed by the consumer in his/her own home with parts and instructions supplied by Svago, such as remote controller replacements that do not require a technician.
- Floor Models and Demonstration Units have a pro-rated Warranty period that begins the day the model is placed on the floor and connected to an electrical outlet by the retail partner. Proof of purchase is required in order to obtain warranty service and parts. Non-warranty parts and service are available at a 'per incident' charge.
- Warranty Coverage Period: warranty coverage starts at the time the consumer purchases their chair. Proof of purchase is required for all warranty repairs. The warranty time period is measured by continuous calendar days based on the seven day week.
- Field Service: Svago Customer Service Department will diagnose and schedule an authorized service provider to repair the chair in the customer's residence.
- Parts: all parts deemed necessary for repairs will be shipped to the customer at no charge by the Svago Service Department.

CONSUMER WARRANTY LIMITATIONS AND EXCLUSIONS

- Warranties are only valid in the 48 contiguous United States and Canada and are contingent upon the consumer operating the chair according to the corresponding instruction manual.
- The warranty only applies to Svago products and does not include any accessories or enhancements.



- Field service requires pre-approval and must be performed by Svago's authorized field service personnel. Field service is only available in the United States and major metropolitan areas in Canada.
- Softening of foam and filling composites in pillows, pads and memory foam occurs naturally and does not constitute a defect under this warranty.
- Fading, wear and piling of fabric occurs naturally and does not constitute a defect under this warranty.
- Natural markings, grain and dye variations in leather do not constitute a defect under this warranty.
- Warranties do not cover any loss or damage resulting from improper installation, unauthorized repairs or modifications, improper use of the electrical/power supply, loss of power, a dropped product, a malfunction or damage of an operating part due to failure to implement the manufacturer's recommended maintenance, transportation damage, theft, abuse, misuse, neglect, vandalism or environmental conditions (fire, floods, rust, corrosion, sand, dirt, windstorm, hail, earthquake or exposure to weather conditions). Loss of use during the period the product is at a repair facility or is otherwise awaiting parts or repair.
- Damage due to shipping and handling does not constitute a defect under this warranty
- Under no circumstances shall Svago or its representatives be liable for indirect consequential or incidental damage (including damages for lost profits, business interruption, bodily injury, medical problems) even if the other party has been advised of the possibility of such damages or possible problems.
- Warranties are non-transferable and shall be in lieu of any other warranty express or implied, including but limited to any implied warranty or merchantability of fitness for particular use.
- Svago's sole liability and the purchaser's exclusive remedy shall be for repair, or at Svago's option, for the replacement of the defective part. Notwithstanding the above, if replacement parts for defective materials are not available, Svago reserves the right to make substitutions in lieu of repair or replacement.
- All warranties begin on the date of purchase, no allowance or extension is offered for delivery and/or installation.
- Warranties do not apply to rental, business, commercial, institutional or other non-residential users.



WARRANTY REGISTRATION FORM

Product Serial No.(Located on product) _____

Purchase Price: _____ Model No: _____

Date Purchased: _____

First Name: _____ Last Name: _____

Address: _____

City: _____ State: _____ Zip Code: _____

Phone: _____

Email: _____

Please mail to:
Svago Manufacturing, Inc.
14515 E DON JULIAN RD
CITY OF INDUSTRY, CA 91746
Tel:1-877-977-0656
Fax:1-800-521-4712

100
95
75
25
5
0

The logo features a stylized white graphic on the left, resembling a curved blade or a dynamic letter 'A'. To its right, the word "SVAGO" is written in a bold, white, sans-serif font. A small "TM" trademark symbol is positioned at the top right of the letter 'O'.

SVAGO™





REDEFINING ZG-RECLINER